

PURICOM EUROPE

C. Aiguafreda 8
Pol. Ind. L'Ametlla Park
08480 L'Ametlla de Vallès
Barcelona · SPAIN

T +34 936 934 310
F +34 936 934 329

puricom@puricom.eu
www.puricom.eu



Distribuidor:

The taste of pureness

The transparency of shapes
comes off smoothly until achieving
the original pureness.





Magma osmotized water

REVERSE OSMOSIS

Reverse osmosis is the best system to obtain quality water through a natural procedure, without the use of chemical products.

Its principle of operation is the same as used in our body, where water is distributed by natural osmosis, thus separating its impurities and turning it to a benefit for our organism.

The Magma reverse osmosis is able to eliminate from 95% to 99% of total dissolved solids (TDS) and 99% of bacterias and viruses, thus giving a sure and pure flavour water for drinking and cooking.

PROPERTIES

THE FLAVOUR OF PURITY

With the Magma osmotized water you'll have healthy water since the first drop, to taste the flavour of food, coffee, tea, juices, etc.

Recover the original flavour for you and yours delighting of whatever you prepare.

COMMODITY OF ECONOMY

With the Magma reverse osmosis, forget about buying, carrying and storing bottled water forever. In addition your only invoice will be that of the public supply company.

A HEALTH OF QUALITY

Great quality water, healthy, highly diuretic and with the adequate percentage of mineral salts that is reflected in a pure flavour.

MAGMA DESIGN

A compact and ergonomic design makes of this osmosis device an exclusive product.

Magma is not only health, but the expression of harmony in one of its prettiest facets, combining an innovative system of operation with a unique design.

Seeing other products, the Magma stands out for its silent operation and for including the state of the art technical solutions as the Aquastop system (which avoids any flooding in our kitchen since it closes automatically the inlet valve when the lesser humidity is detected inside the equipment) or the automatic cleaning of reverse osmosis membrane (this is the main compenent of Magma) that, in addition to lengthening of the lifetime of the equipment, brings us a better quality of water.



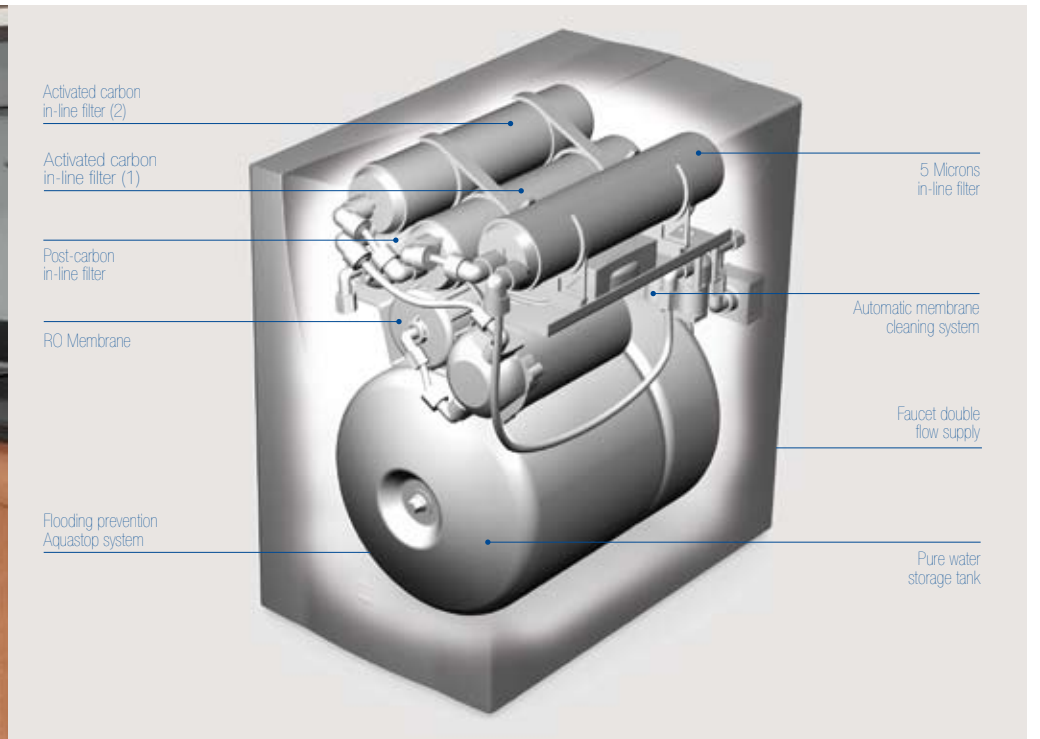

Technical features



Equipped with double flow system for an easy and comfortable filling of pure water.



Leaking sensor.



Easy maintenance. Direct access.



The content of the filter is made by **CALGON (USA)**. NSF-Quality certified.



BACTERIOSTATIC Silver Post-Carbon Filter. NSF certificate.



AUTO FLUSHING. Membrane self-cleaning.



Provided with a blocking device for connections.



All tubes and accessories are from **John Guest**, whose maximum quality is certified by **NSF**.



New **Green Filter CS** Filter. Maximum security and easy maintenance.



Ecological product. Contains a control device to reduce water consumption.



Security system to connect tubes.



High quality membrane manufactured by **Dow Chemical** with NSF certificate.



External transformer.

MAIN ASPECTS

The Magma reverse osmosis allows to be installed easily without affecting the look of your kitchen. Magma includes all necessary accessories for its use and installation. The pack includes:

- Osmosis device
- Present-day design high quality faucet
- 1/4" Valve
- 3/8 - 3/8 Plug
- Drain clamp
- Connection tubing
- User Manual

TECHNICAL FEATURES

	MAGMA	MAGMA PUMP
- Sediment Filter (units)	1	1
- Chlorine remove Filter(units)	2	2
- Membrane Capacity (GPD)	50	50
- Posfilter (units)	1	1
- Purified water production (l/day)	140*	140*
- Impurities mean rejection	95-98%	95-99%
- Supply water maximum TDS in mg/l (ppm)	1000	1500
- Supply water min.-max. temperature in °C	2-38	2-38
- Supply water min.-max. pressure in bar	3-6	1-2,5
- Storage tank total capacity (l)	10	10
- Usable volume of storage tank (l)	7	7

*According to the specifications of the membrane.

REJECTION PERCENTAGE

	MAGMA	MAGMA PUMP	Potential Pollutants	Other elements
- Aquastop system	Yes	Yes	Barium 98%	Bicarbonates 94%
- Automatic membrane cleaning system	Yes	Yes	Cadmium 96%	Calcium 95%
- Power Supply	240VAC 50Hz/24 VDC	240 VAC 50Hz/24 VDC	Chromium 99%	Magnesium 96%
- Electrical Safety Certification	CE	CE	Mecury 83%	Nickel 96%
- Maximum power consumption (W)	12	29	Nitrates 77%	Sulphates 99%
- Dimensions, width x depth x height (cm)	24,5x40x43,5	24,5x40x43,5	Lead 82%	Tanins 97%
- Weight (kg)	6	9	Copper 98%	Zinc 97%

⚠ The Magma must be installed in bacteriologically drinkable waters.

OPTIONAL EQUIPMENT AVAILABLE:

Auxiliar storage tanks, UV germicide lamp, remineralizer, special membranes (ultrafiltration).

WE RESERVE THE RIGHT TO INTRODUCE TOTAL OR PARTIAL VARIATIONS IN OUR PRODUCTS AND THE CONTENT OF THIS DOCUMENT WITHOUT PRIOR WARNING.