

FC-4500 ROP

**TECHNICAL/USER MANUAL AND
THE SERVICE BOOK**

USER MANUAL

INDEX	P
0 Main features	5
1 Unpacking	8
2 Introduction	8
3 Types of FC-4500 fountain treatments	8
4 Preliminary warnings	9
5 Equipment Operation	10
6 Installation	11
7 Flushing of the carbon filters	11
8 Checking the system for leaks, shutdown and start-up. (RO)	12
9 Cleaning and maintenance	12
10 Sanitization procedure	13
11 Identification of the management components and control	15
12 User interface	16
13 Button functions	16
14 How to access the filters	17
15 Fault identification table of the display	17
16 How to activate the hot water function	17

TECHNICAL MANUAL

INDEX	P
17 Technical Features	18
18 Troubleshooting	21
19 Warranty	24
20 Installation log sheet	25
21 Maintenance service	26

This appliance is intended primarily for domestic and similar applications.

- Personal cooking areas in stores, offices and other work environments.
- Rural and guest accommodations in hotels, motels and other residential type environments.
- Bed and breakf

More technical information at:

www.wtreatmentresources.com/824JG0P0XKI.html



TECHNICAL DATA FC-4500

O. MAIN FEATURES



DIRECT ACCESS
EASY ACCESS AND MAINTENANCE



COLUMBIA FILTERS
EXCLUSIVE FILTERS
MAXIMUM SAFETY AND HYGIENE



CLICK
FAST CONNECTIONS AND
MAXIMUM SECURITY



PRESSURE PUMP
INCREASED PRODUCTION
AND OUTPUT



SOLENOID VALVE
IMMEDIATE CONTROL
BUILT-IN SAFETY NETTING



REVERSE OSMOSIS
EQUIPMENT WITH REVERSE
OSMOSIS SYSTEM AND THE PUMP



LEAK SENSOR
WATER LEAK DETECTION SYSTEM



UV
ULTRAVIOLET LIGHT BACTERICIDAL
SYSTEM



WATER QUALITY CONTROL
TDS MONITORING OF WATER
(OPTIONAL)



COLD
COLD WATER
PRODUCTION



HOT
COLD WATER
PRODUCTION



AMBIENT
PRODUCTION OF WATER
AT ROOM TEMPERATURE



LED
MULTIFUNCTION INFORMATION
SYSTEM WITH DISPLAY



ENERGY SAVE
ENERGY SAVING SYSTEM A
BRIGHTNESS SENSOR ALLOWS PART OF
THE FOUNTAIN TO BE LEFT ON "STAND
BY" DURING THE NIGHT TO REDUCE
POWER CONSUMPTION.



AUTO FLUSHING
SISTEMA AUTOMÁTICO DE
LIMPIEZA DE MEMBRANA



Keep this manual, which includes the service book and warranty sections, in order to provide you with better after-sales service.

SAFETY INSTRUCTIONS

The following safety warnings and instructions are provided to avoid injury to the user and to prevent damage to the user's property. However, it is important to take the necessary precautions and exercise care during installation, maintenance, cleaning and operation.

Children/adults/pets

Children and others who are unaware of the risks involved in using the device could be injured or have their lives endangered. Therefore, please note:

- The appliance is not intended for use by persons under 8 years of age, persons with reduced physical, sensory or mental capabilities or lack of experience and knowledge unless they have been given supervision or instruction concerning use of the appliance in a safe way and have been made aware of the hazards involved.
- Children should not play with this appliance.
- Children should not be allowed to carry out cleaning or maintenance work on the appliance without supervision.

Warning: Risk of suffocation!

Do not allow children to play with the packaging/plastic or parts of the packaging, as they could become entangled or cover their heads with them and be suffocated. Keep packaging, plastics and packaging parts out of the reach of children.

Assembly. Warning

Danger of electric shock/fire/damage to property/damage to the unit!

If the unit is installed incorrectly, it can lead to dangerous circumstances. Ensure that the following conditions are met:

- The mains voltage at the socket outlet must correspond to the rated voltage specified on the device (rating plate).

The mains voltage at the socket must correspond to the rated voltage specified on the device (nameplate).

- The mains plug and the socket with protective contact must match and the earthing system must be correctly installed.

- The installation must have a suitable cross-section.

The mains plug must be accessible at all times. If this is not possible, in order to comply with the relevant safety regulations, a switch (two-pole switch) must be permanently integrated into the installation in accordance with the electrical installation regulations.

If the power cord of the appliance is modified or damaged, it may cause an electric shock, short circuit or fire due to overheating.

The mains cable must not be bent, crushed or modified and must not come into contact with heat sources.

The use of extension cords or extension leads may cause an ignition due to overheating or short-circuiting.

Connect the appliance directly to a properly installed and grounded outlet. Do not use extension cords, power strips or multiple connectors.

Warning: Danger of injury!

The appliance is very heavy. Lifting the unit may cause injury. Always lift the unit with assistance.

If the hoses and mains cables are not correctly routed, there is a risk of disconnection and injury.

Route hoses and cables in such a way that there is no risk of disconnection.

Caution! Danger of material damage/damage to the unit.

If the water pressure is too high or too low, the unit may not function properly. In addition, material damage or damage to the appliance may occur. Make sure that the water pressure in the water supply system

Make sure that the water pressure in the water supply system is at least 100 kPa (1 bar) and does not exceed 500 kPa (5 bar).

If the water pipes are modified or damaged, this may result in material damage or damage to the unit. The water pipes must not be bent, crushed, modified or cut.

- The use of hoses supplied by other brands to connect the water supply may result in damage to property or damage to the appliance. Use only the hoses supplied with the appliance or original replacement hoses.

Cleaning/maintenance

Warning: Risk of death!

The unit is electrically operated. There is a danger of electric shock. There is a danger of electric shock if live components are touched, so please observe the following:

- Switch off the unit. Disconnect the device from the mains (pull out the mains plug).

- Never grasp the mains plug with wet hands.

- When disconnecting the mains plug from the socket, always grasp the plug itself and never the mains cable, as this could damage it.

- Do not make any technical modifications to the unit or its components. Any repair or other work on the appliance must be carried out by our service department or an electrician. The same applies to the replacement of the mains cable (if necessary).

- Replacement mains cables can be ordered by contacting our service department.

1. UNPACKING

Before installation and start-up, it is important to check the box and the condition of the equipment to ensure that it has not been damaged during transport.

! **Caution:** Claims for damage during transport must be submitted together with the delivery note or invoice to your distributor, enclosing the name of the carrier within 24 hours after receipt of the goods. Remove the equipment and accessories from their cardboard packaging, removing the corresponding protections.

! **Caution:** Properly dispose of and keep plastic bags out of the reach of children, as they can be a danger to them. Inside you will find (depending on the model): Water treatment equipment, installation accessories and documentation. The materials used in the packaging are recyclable and must be disposed of in the appropriate separate collection containers or at the local waste collection center.



This product must not be disposed of with normal municipal waste. When the equipment has reached the end of its useful life, it should be handed over to the company or center where the equipment was purchased, or to a clean point or specific local center for the recovery of materials, indicating that it has electrical and electronic components and refrigerant gas. The correct collection and treatment of unusable equipment helps to conserve natural resources and also to avoid potential risks to public health.

The correct collection and treatment of unusable equipment helps to conserve natural resources and also to avoid potential risks to public health.

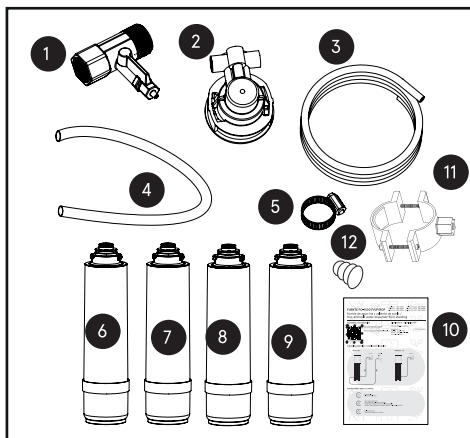

1.1 Accessories included

- 1 Inlet stopcock
- 2 Filter rinsing head
- 3 Inlet 1/4" pipe
- 4 Drain pipe Ø 18
- 5 Flange for drain pipe
- 6 Sediment pre-filter
- 7 Carbon pre-filter
- 8 RO membrane
- 9 Carbon post-filter
- 10 Reduced manual QR
- 11 Drain collar
- 12 Drip tray plug

2. INTRODUCTION

Congratulations. You have purchased one of the best water treatment systems on the market for office use.

This equipment will help you to improve the characteristics of your water by providing you with the highest quality, low mineralization water.

Your equipment will provide you with different benefits and benefits:

- It is a physical system that does not use or add chemicals to the water.
- It provides high quality water.
- It has a low maintenance cost.
- It ensures high production.

3. FOUNTAIN FILTERS

Sediment filter.

Filtration is the process of separating suspended solids in water through a porous medium, also called a filter. Water passes through the filter pores, but particles larger than the filter pores are retained in the filter, resulting in clearer water. Columbia Fountains incorporate 5µm filters.

Activated carbon filter.

Activated carbon is used to remove chlorine from water, as well as to improve taste, odor and remove some organic compounds due to its high adsorption capacity. Columbia Fountains incorporate activated carbon block.

Reverse osmosis membrane

Natural or direct osmosis is the most common in nature, since semi-permeable membranes are part of the vast majority of organisms (e.g. plant roots, organs of our own body, cell membranes, etc.).

When two solutions of different salt concentrations are separated by a semipermeable membrane, water naturally flows from the solution of lower concentration to the solution of higher concentration. This flow continues until the concentrations on both sides of the

membrane are equalized.

When trying to reverse this process and achieve a flow of water with a lower concentration of salts from one with a higher concentration, sufficient pressure of the water with the higher concentration must be applied to the membrane in order to overcome the tendency and natural flow of the system.

This process is called reverse osmosis. At present, reverse osmosis is one of the best methods to improve the characteristics of water by means of a physical system (without the use of chemical products).

The water to be treated exerts pressure on the permeable membrane, so that part of it will pass through the pores of the membrane (osmosis water), while the rest of the water (rejected or with a high concentration of salts) will be diverted to the drain. (Fig. 1).

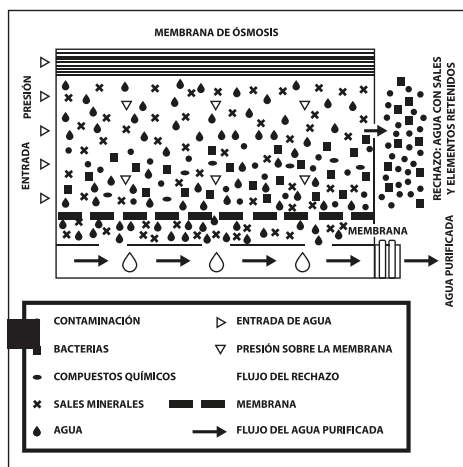

4. PRELIMINARY WARNINGS



These units are supplied with refrigerant gas, ISOBUTANE (R-600a), which is a natural gas with no harmful effects on the environment, but is flammable.

- The appliance must be transported and moved with the utmost care so that it is not knocked or shaken excessively. Failure to do so could result in the appliance being put out of service.

- Keep the ventilation openings of the appliance or the built-in structure free of obstructions.

- Do not damage the cooling circuit. Damage to the cooling circuit, with possible refrigerant gas leakage, could create explosion hazards caused by sparks or external flames.

- Under no circumstances operate your appliance if it appears to be damaged.

- In the event of a fault, contact your technical

service, ventilate the room where the appliance is located and avoid open flames or work on the appliance.

- For recycling, contact your local waste disposal service or the seller. The appliance must be transported without damaging the cooling circuit.

- This appliance is intended for use in domestic and similar applications such as staff kitchen areas in stores, offices and other work environments; rural and customer accommodation in hotels, motels and other residential type environments; bed and breakfast type environments; catering services and similar non-retail applications.

Caution: Carefully read and retain this manual, prior to installation and commissioning of the equipment. If you have any questions about the installation, use or maintenance of this equipment, please contact your distributor's Technical Assistance Service (T.A.S.).

! Attention: This equipment ARE NOT DRINKING WATER TREATMENT SYSTEMS. If the water to be treated comes from a public water supply (and therefore complies with current legislation), this equipment will substantially improve the quality of the water. Otherwise, a physicochemical and bacteriological analysis of the water will be necessary, in order to ensure its correct potabilization by applying the appropriate techniques and equipment for each need, PRIOR TO INSTALLATION of the equipment. Contact your distributor for advice on the most suitable treatment for your case.

Water treatment equipment requires periodic maintenance by qualified technical personnel in order to guarantee the quality of the water produced and supplied.

4.1 Conditions for the correct operation of the equipment.

- The equipment must not be supplied with hot water ($T > 40^{\circ}\text{C}$).

- The ambient temperature must be between 4°C and 45°C .

Some models are equipped with a pump. In the event that the mains pressure is higher than 2.5 bar, a pressure regulator should be installed before the water enters the unit, set at a maximum pressure of 2.5 bar.

For water with salinity higher than 2000 ppm, consult your distributor. It is recommended that the water to be treated be decalcified or with a maximum hardness of 15°HF in order to obtain optimum performance of the equipment. In the event that the water to be treated has a hardness higher than 15°HF , a reduction in the life of the membrane and in the performance of the equipment could occur.

- In case the water to be treated contains:

- High concentrations of iron and manganese (Greater than 1ppm measured in the machine rejection).

- Prolonged hyperchlorination over time.

- Sludge or turbidity higher than 3 NTU.

- A nitrate concentration greater than

100 ppm.

- Sulfate concentration greater than 250 ppm.
- Contact your distributor to recommend the most appropriate pre-treatment for your case, to ensure the correct operation of the equipment, avoid damage to components and guarantee the quality of the water supplied.

4.2 Warnings prior to installation

In the event that the installation of the equipment in the home or business needs to be prepared in order to install it in the intended location, it must be done in accordance with national standards for indoor water supply and electrical installations.

COLUMBIA devices require an electrical outlet within a distance of less than 1 meter.

The COLUMBIA units must not be installed lying or inclined.

lying down or inclined. They must be placed on a flat surface for proper and safe operation.

- The installation site must have sufficient space for the unit itself, its accessories, connections and for convenient maintenance.

Maintain a minimum clearance of 10 cm from the sides and rear wall to ensure proper ventilation of the unit.

Under no circumstances should the equipment be installed outdoors.

! **ATTENTION: The unit must not be connected to the power supply directly, it must be left to stand for 2 hours after it has been placed in the desired installation position. This is very important to ensure correct operation of the system, otherwise the compressor may be damaged. The manufacturer will not be held responsible for The manufacturer will not be liable for any damage to the equipment in this case.**

4.3. Warnings on the use of the unit

- When you are going to be absent for more than a week, close the water inlet tap to the unit, empty it and disconnect it from the power supply. When you return, turn on the power supply, open the water inlet tap and empty the storage tank twice before using water.

Caution: After a prolonged period (more than one month) in which the equipment has not been in operation or producing water, contact your dealer for proper sanitizing and maintenance.

! **Caution: Special attention should be paid to cleaning and sanitizing the front dispensers on a regular basis and especially at the time of periodic maintenance and sanitizing. For this purpose, use the sanitizing spray and single-use absorbent paper (See chapter Sanitizing).**

! **Caution: The water provided by the osmosis equipment is of LOW MINERALIZATION. The mineral salts needed by the human body are mainly provided by food, and to a lesser extent by drinking water.**

5. OPERATION OF THE EQUIPMENT

5.1 How to draw water from your dispenser.

See chapter 12 User Interface for how to draw water.

5.2 Using the management and control components

See chapter 11 Component identification and how the management and control components work.

5.3 Basic operation of the system

The mains water to be treated enters the unit through the turbidity filter and carbon filter. In this filtration stage, suspended particles, chlorine, its derivatives and other organic substances are retained. The water, after the filtration stage, is then fed to the reverse osmosis membrane. The equipment may incorporate a pump to increase the pressure. The pressure of the water on the membrane makes the reverse osmosis process possible. The water then passes through a post-filter to remove possible odors and tastes.

The treated water is stored in an accumulation tank for later consumption. The rejected water or water with excess salts and other dissolved substances is directed to the drain for disposal.

When the accumulation tank is full, the equipment stops its operation by means of a level switch.

When water is demanded by pressing the front buttons of the equipment, the water accumulated in the cold, hot and ambient water tanks flows to the outlet nozzles

! **Attention: There are slight variations in operation, depending on the model. Please read the corresponding section of the Technical Manual.**

6. INSTALLATION

The installation of your Columbia Fountain should be carried out by sufficiently qualified personnel. Consult your dealer if in doubt.

! **Caution: Since the appliance to be installed improves the quality of the water to be consumed, all tools used for assembly and installation must be clean and must not be contaminated or impregnated with grease, oil or oxides. Use tools exclusively for cutting pipes, handling of the membrane, etc.**

! **Attention: The work must be carried out with an adequate hygienic attitude and conditions, taking extreme precautions in everything related to materials and components that are going to be in contact with the water to be treated or consumed.**

! **Attention: Avoid the risks of external contamination of the equipment due to inadequate handling, using gloves, hand sanitizing gel or washing your hands as many times as necessary throughout the installation, start-up and maintenance of the equipment. Install the drain collar (picture 2) and inlet adapter (picture 3) and connect them to the respective connectors on the unit.**

The drain pipe can be directed upwards vertically, a

maximum of 2.5 meters and another 5 meters horizontally. This model includes a connection for emptying the drip tray (see Technical Manual), in this case this tube must be directed to a drain that is at a lower height than the drip tray as it will be emptied by the weight of the water.

In case there is no drain nearby and therefore the tray cannot be connected to the drain, place the rubber plug supplied with the "ACCESSORIES INCLUDED" (figure 12) at the tray outlet.

! Attention: Some of the installation accessories may vary depending on the model and region in which the equipment is distributed.

Use appropriate tools and sealants to ensure the tightness of the connections.

40 mm drain clamp

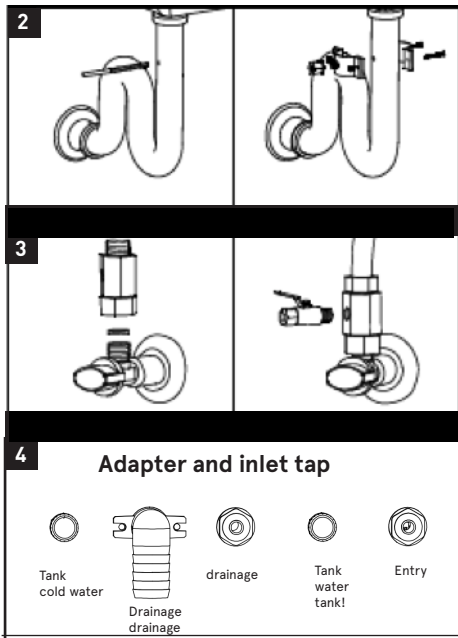

7. RINSING IN INSTALLATION OF THE FILTERS

See chapter 14 of the Technical Manual for how to access the filters.

It is necessary to remove the granulated carbon dust from the filters that is generated during transport and handling of the equipment and the corresponding cartridges. This dust must be removed as it could completely or partially clog the reverse osmosis membrane and cause the equipment to malfunction.

! Attention: Do not wash the carbon pre-filters through the front dispensers, as the carbon dust that is intended to be eliminated will enter the equip-

ment's deposits and may cause malfunction and fouling of the equipment and/or reduction of the useful life of certain components.

Take the rinsing head supplied with the "INCLUDED ACCESSORIES" (figure 2) and install it on the inlet pipe. Unseal the carbon pre-filter and attach it to the head. Route the outlet tube to a container or drain and open the inlet stopcock. Let the water run until it runs clear. Rinse both the pre-filter and post-filter. After flushing the filters, leave all tubing and components in their original position and connections.

8. SYSTEM TIGHTNESS TEST, STOP AND START (RO)

Keep the inlet stopcock open and keep the equipment electrically powered by performing an ocular check of the system to ensure that there are no leaks (for about 1 minute).

To ensure proper operation of the main components of the system, remove the top cover of the equipment to access the tank, remove the tank cover, using gloves, lift the float of the upper tank level switch 5, wait about 10 seconds until the equipment stops production. Release the float and wait 10 seconds to check that the equipment starts up again.

Release the float and wait 10 seconds to check that the equipment starts up again.

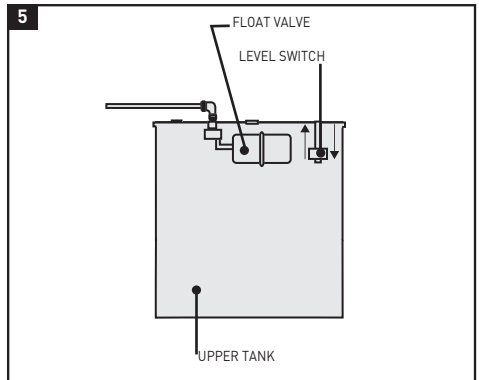

9. CLEANING AND MAINTENANCE

9.1 Cleaning the equipment

- Always unplug the unit from the power supply before cleaning the unit.
- Clean the exterior surfaces of the unit with a cloth dampened with water and neutral soap.
- Never use detergent or chemicals.
- Do not spray water directly on the surface of the equipment.
- If the condenser accumulates dust or other unknown substances, clean it with a cloth dampened with water and neutral soap.
- After cleaning, dry the unit completely before plugging it into the power supply.
- Empty the drip tray daily.

9.2 Maintenance of the water treatment system

! **Attention:** Some components of your unit, such as the pre-filters, membrane and post-filters (depending on the model), are consumables that have a limited service life. The duration will depend on the local water quality, consumption, type of use and specific aspects of the water to be treated such as extreme turbidity, high chlorination, excess iron.

! **Attention:** In order to guarantee the quality of the water supplied by your equipment, it should be regularly maintained. periodic maintenance.

Recommended maintenance
Pre-filter sediment: At least every 12 months*
Carbon pre-filter: At least every 12 months*
Osmosis membrane: Approximately every 3 years (for soft water to be treated (hardness >15°HF))
Post-filter: At least every 12 months*
Sanitizing: At start-up. At least every 12 months depending on use. Every time the equipment's water-contacting components are accessed or no water has been consumed for more than one month

* Depending on the intended use and characteristics of the water to be treated.

Maintenance must be carried out by trained personnel, who must handle the equipment properly, as well as use original spare parts to maintain the characteristics, warranty, certifications and performance of the equipment and thus preserve the quality of the water dispensed.

! **Attention:** The use of non-original spare parts, installation outside the limits of operation and start-up, inadequate maintenance or use, may lead to the loss of the warranty, as well as the invalidation of the certifications received by the equipment.

An excess of any compound (total chlorine, turbidity, hardness, etc.) may cause a reduction in the life of filters and certain components. These maintenance procedures are for guidance only.

! **Attention:** All consumables are supplied in specially designed individual packaging to ensure hygienic storage and transport conditions. to ensure hygienic storage and transport conditions. Take hygienic precautions after removing the consumables from their packaging and when handling the various connectors and components.

! **Caution:** Before disassembling the equipment, make sure that you have all the material you will need to carry out the maintenance operations and the space required. the maintenance operations and the space required for this purpose. Work in a well-lit place, in adequate hygienic conditions and with enough space to carry out the operations properly.

Change filters properly, according to the equipment model and type of filter. Ensure the tightness of the connections and the original hydraulic configuration of the system. See the Technical Manual for the filters required according to your equipment model and how to access the filters. Sanitize the equipment following the indications described in the Sanitizing Procedure.

! **Attention:** In case of detecting that the dispensed water does not comply with the national legislation in force, close the inlet tap of the equipment, empty it through the tap, disconnect it electrically and contact your service technician.

10. SANITIZATION PROCEDURE

Necessary material:

- Manual valve.
- Dosing cup with connectors.
- Hydrogen peroxide (0.5 l). (sanitizing product)
- Single-use vinyl gloves.
- Hydrogen peroxide detection strips.
- Sanitizing spray. (Hydrogen peroxide)
- Paper napkin.

Sanitize the equipment during start-up, when necessary (whenever there is a risk of contamination of the equipment by handling components in contact with water) or at the indicated intervals.

To do this, follow the steps below:

! **Caution:** The water used during the sanitizing process must be potable water (from the public distribution network, complying with the corresponding potability requirements of RD 140 / 2003, European directive 98 / 83 or local legislation in force).

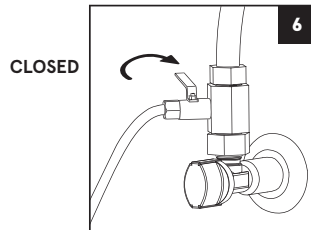

- Keep the inlet valve closed (6) and empty the accumulation tank through the front dispensers (see chapter "how to extract water").

- The sanitizing process must be carried out with the new pre-filters and after-filters installed and properly rinsed beforehand, with carbon dust properly removed from the pre-filters and post-filters.

- Use single-use vinyl gloves to handle sanitizing products.

10.1 Sanitizing the pre-filters and membrane

- Keep the water heating system turned off during the whole sanitizing process. Insert the dosing cup into the inlet pipe to the equipment.

To do this:

- Disconnect the inlet pipe to the equipment marked "IN", and insert the dosing cup between the stopcock and the water inlet of the equipment (8). For greater convenience and ease of access during sanitizing and opening and closing operations of the inlet valve, a manual valve in closed position can be inserted together with the sanitizing dosing cup, which will perform the same functions as the equipment inlet stopcock.

- Once the assembly has been installed, keep the new inlet valve closed and open the inlet stopcock (9). The dosing cup should initially be empty.

- Pour 100 ml of sanitizing product into the dosing cup inserted in the inlet of the unit (10). Screw the cup correctly to its head.

- On RO models. Connect the equipment to the power supply.

- Open the water inlet stopcock to the equipment, allowing it to start up and letting the sanitizing product be pushed into it. Keep the inlet valve in that position and let the equipment run.

Close the inlet stopcock (11) and unplug the unit from the power supply, wait until the unit stops discharging water from the discharge outlet to the drain (osmosis models only).

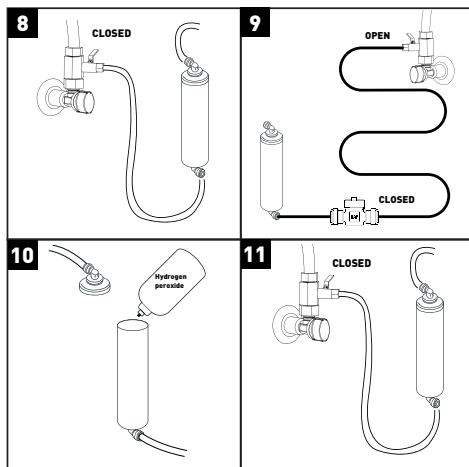

Let the filters soaked with the Product stand for 20 minutes. In the meantime proceed to sanitize the reservoirs.

10.2 Sanitizing the reservoirs and the front dispenser

- Empty the dosing cup. Before opening it, have a container within easy reach where you can empty it, as it may be full of water. Uninstall the dosing cup.

- Remove the top cover of the unit to access the reservoir and remove the reservoir cap.

- Fill the upper tank of the unit halfway with tap water. To do this, use the same feeding tube as the unit or fill jugs and pour them into the tank (12).

- Pour 25 ml of sanitizing product into the tank for each liter of total accumulation capacity of the unit (cold, hot and reserve tank).

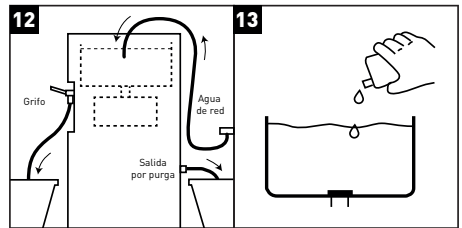

Finish filling the upper tank in order to mix the sanitizing product.

- Draw 1 glass of water for each front dispenser and let the mixture stand in the tanks for 20 minutes.

- Sanitize the nozzles of the front dispensers using cotton swabs and sanitizing spray.

- Completely empty the reservoirs through the front dispensers and purge outlet (12). Refill the reservoirs and empty them to rinse out the residual sanitizer.

- Replace the top covers of the tank and the unit. Remove the accessories used for sanitizing and reconnect the supply hose to the inlet (IN) of the unit.

- Open the stopcock and power the equipment to start it up.

- Use the sanitizing product detector strips (318701) to verify that the equipment is properly rinsed, make the necessary drains in case of detecting remains of sanitizing product.

11. IDENTIFICATION OF THE MANAGEMENT AND CONTROL COMPONENTS

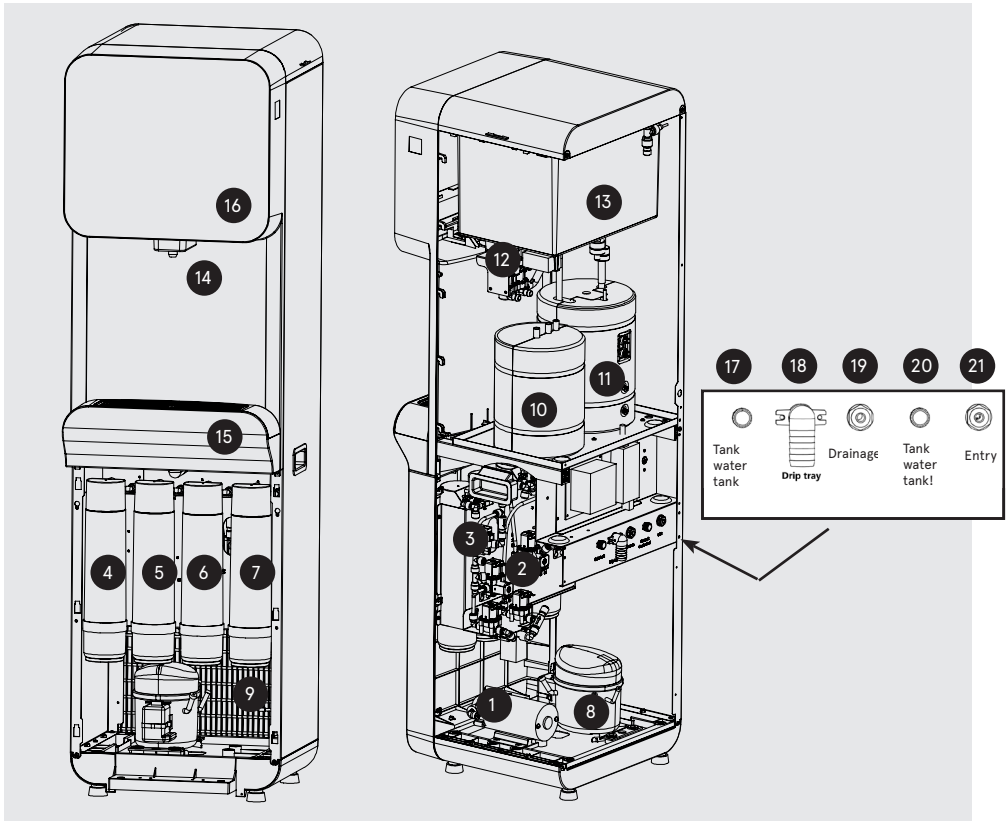

1 Booster pump. Improves production and reduction of dissolved solids in the water.

2 Automatic solenoid valve. Controls water inflow through program settings.

3 High pressure switch. When the fountain tank fills, the fill solenoid valve shuts off, then the high pressure switch shuts off the pump.

4 Sediment filter. Retains the particles in the water.

5 Carbon block pre-filter. Reduces chlorine in the water and improves taste.

6 Reverse osmosis membrane. Reduces the amount of sediment in the water.

7 Carbon block post-filter. Improves the taste of the water.

8 Compressor. It is responsible for recirculating the refrigerant gas through the refrigeration circuit in order to cool the water in the cold water tank.

9 Condenser. Part of the refrigeration circuit where the refrigerant gas is condensed. It acts as a heat exchanger to cool the refrigerant gas.

10 Chilled water tank. This is where the evaporator coil is located where the refrigerant gas cools the water.

11 Hot water tank. A heating element on a stainless

steel rod heats the water. It is controlled by the temperature sensor.

12 UV lamp. It is switched on when cold or ambient water is consumed to eliminate bacteria from the water.

13 Reserve tank. This feeds the hot and cold water tanks, as well as supplying ambient water.

14 Outlet nozzle. Outlet of the treated water, both cold and hot and ambient.

15 Drip tray.

16 Front display and selector buttons.

17 Cold water tank drain. Remove this plug in case the cold water tank needs to be emptied.

18 Tray drain. Connect this outlet to a nearby drain less than 40 cm from the floor so that the drip tray (optional) can be emptied.

19 Reject drain. Connect this 1/4" outlet to a nearby drain for proper reverse osmosis operation.

20 Hot water tank drain. Remove this plug in case the hot water tank needs to be emptied.

21 Water inlet connection. Connect this connection with 1/4" pipe to a water inlet in order to supply the water source.

12. USER INTERFACE

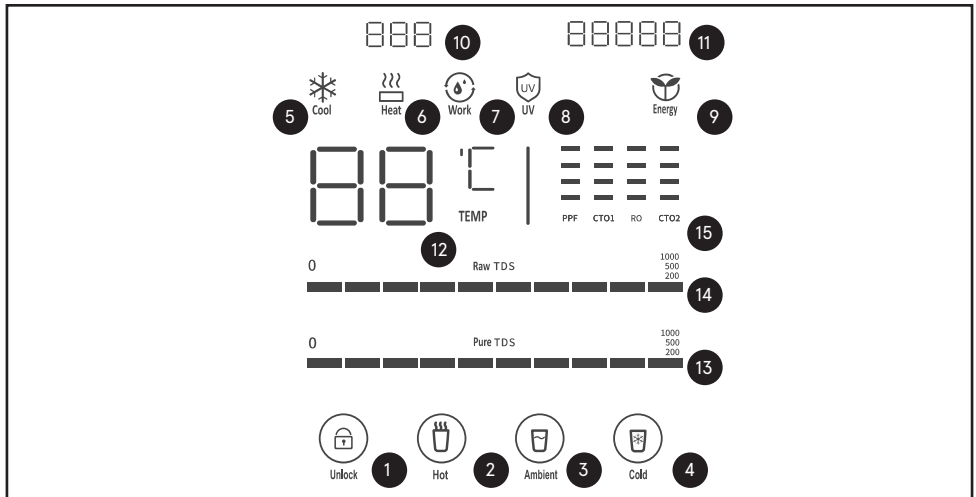

1 Unlocking. Hot water can only be extracted after unlocking it by pressing this button.

2 Hot water. Touch the unlock button and then touch the hot water button to draw hot water.

3 Room temperature water. Touch this button to draw ambient water.

4 Cold water. Touch this button to draw cold water.

5- Cooling. This lighted icon indicates that the fountain is cooling the water in the cold water tank.

6 Heating. This lighted icon indicates that the source is heating the water in the hot water reservoir.

7 Filtering. This lit icon indicates that the fountain is filling the reservoir tank with osmosis water.

8 UV light. This light indicates that the UV lamp is sterilizing. It will only activate when there is cold or ambient water consumption.

9 Energy saving. This lit icon indicates that the energy saving system has deactivated the water heater to save energy.

10 Remaining days of service (optional). If the equipment is working properly, the remaining days for maintenance will be displayed. In case of a malfunction, the error code will be displayed. See the fault identification table in chapter 6 of the technical manual.8 8

11 Plastic bottles saved to the environment. The estimated value of water bottles saved to the environment is displayed.

12 Temperature. While the fountain is not in use, the temperature of cold and hot water is displayed alternately. When cold or hot water is drawn, the temperature of this water is displayed.

13 Inlet TDS (optional). Indicator of the TDS (total dissolved solids) of the mains water. If the TDS has a value between 0~200 PPM each bar represents 20 PPM. If the TDS has a value between 0~500 PPM, each bar represents 50 PPM. If the TDS has a value between 0~1000 PPM, each bar represents 100 PPM.

14 Osmosis TDS (optional). Indicator of the TDS (total dissolved solids) of the osmosis water. If the TDS has a value between 0~200 PPM each bar represents 20

PPM. If the TDS has a value between 0~500 PPM, each bar represents 50 PPM. If the TDS has a value between 0~1000 PPM, each bar represents 100 PPM.

15 Filter life (optional). There are four columns of four segments, each column indicates one of the filters: PPF (sediment pre-filter), CTO1 (carbon pre-filter), RO (reverse osmosis membrane) and CTO2 (carbon post-filter). The four lit segments indicate 100% filter life when new, and one segment turns off every 25% of filter life usage. When 100% filter life is exhausted, the filter flashes. After changing the filter and resetting the icons, the icons turn back on at 100%.

13. BUTTON FUNCTIONS

How to draw water from the dispenser

- **Draw cold water:** place the container centered on the tray and touch the cold water button once to start dispensing. Touch the button again to stop dispensing. After water dispensing has started, it will stop automatically after one minute if the button is not touched again.

- **Draw ambient water:** place the centered container on the tray and touch the ambient water button once to start dispensing. Touch the button again to stop dispensing. After water dispensing has started, it will automatically stop after one minute if the button is not touched again.

- **Draw hot water:** place the centered container on the tray and touch the unlock button once and then the hot water button to start dispensing. Touch the button again to stop dispensing. After water dispensing has started, it will automatically stop after one minute if the button is not touched again.

This fountain has an advanced options menu that allows you to disable the hot and cold water function among other options. Contact your service technician if necessary.

14 HOW TO ACCESS THE FILTERS

Remove the two bottom screws from the bottom front of the fountain. Grasp the lower front firmly with both hands and pull it downwards, then outwards.

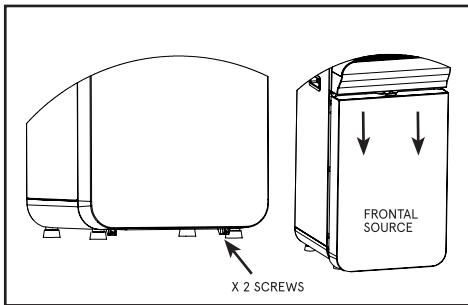

15. DISPLAY FAULT IDENTIFICATION CHART

E02 Abnormal operation. The equipment has been filtering water for 16 hours without stopping.

E05 Abnormal heating. The equipment has not reached 50°C after more than 1h of heating.

E07 Water leakage. Water has been detected in the leak sensor for more than 15 seconds.

E09 Abnormal hot water temperature.

Temperature outside its limits is detected.

E18 Abnormal cold water temperature. A temperature outside its limits is detected.

E22 Abnormal water level. Abnormal water level control position is detected.

E35 Abnormal communication. Communication failure between the display and the electronic control.

16. HOW TO ACTIVATE THE HOT WATER FUNCTION

Press and hold the unlock and cold water buttons simultaneously for 10 seconds to enter the settings menu. Press the cold water button several times until you see the code C21.

Press the hot water button to change option number 1. Press and hold the cold water button for 5 seconds to save the change and exit the settings menu. The hot water function is now activated.

17. TECHNICAL CHARACTERISTICS

APPLICATION

ROP Model (Reverse Osmosis)

Use

Improvement of drinking water characteristics (complying with the requirements of the European Drinking Water Directive 98/83 or its national transpositions in the different member states of the European Community).

Modifications by reduction or addition

- Water treatment by reverse osmosis is capable of reducing the concentration of salts and other substances by high percentages.

- Minimum reduction* of certain compounds and parameters:

Sodium - 90

Calcium - 90

Sulfate - 90%

Chloride - 90%

Total Hardness - 90%

Conductivity - 90%.

(*) Depending on the characteristics of the water to be treated (at the membrane outlet). These values may vary depending on the type of post-filter incorporated in the equipment.

OPERATING LIMITS

ROP

Pressure (max. / min.)

2.5 bar (250 kPa)

TDS (max.)

1 bar (100 kPa)

Temperature (max. / min.)

2000 ppm 40°C - 2°C

Hardness (max.)

15°HF**

TECHNICAL DATA

ROP

Control type:

Level switch.

Inlet solenoid valve.

Cold water temperature sensor

Hot water temperature sensor.

Safety system:

Hot water safety thermal protector.

Hot water safety thermal protector.

Float valve Anti-overflow.

Inlet connection:

1/4"

Drain connection:

1/4"

Wall adapter:

1/2"

Drain collar:

Abrazadera para tubo de desagüe de 40 mm

Drain connection:

18 mm

TECHNICAL DATA

ROP

Treatment
 Pre Filter sediment (x1)
 Pre Carbon (x1)
 Membrane RO 150 GPD (x1)

Pre- and Post-filter connection:
 Inlet: Bayonet
 Outlet: Bayonet



Membrane Connection
 Inlet: Bayonet
 Outlet (RO): Bayonet

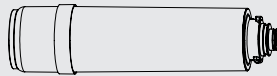

Dimensions: (A x B x C) 1410 x 400 x 440 x 275 mm.
Net weight: 36 kg

TOTAL TANK VOLUME 3 liters
Cold water tank: 5 liters
Hot water tank: 12 liters
Reserve:
Power supply 220 - 240 Vac
COOLING REFRIGERATION
Compressor power:
Condenser: 150 W
Temperature control: Capillary type
 R600a
 Temperature probe
HEATING SYSTEM
Heater:
Heater power:
Temperature control
Overheating protection: Internal resistance
 1500 W
 Temperature probe
 Bi-metal I self-assembly

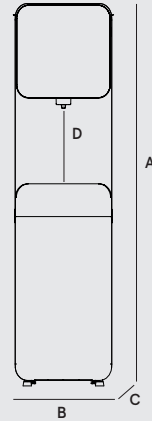

HYDRAULIC DIAGRAM

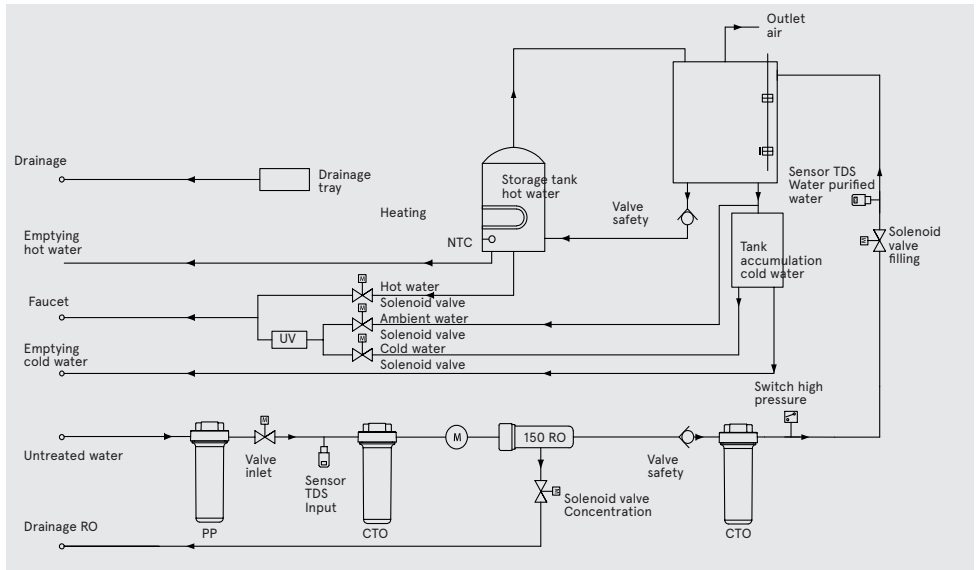

ELECTRONIC CIRCUIT DIAGRAM

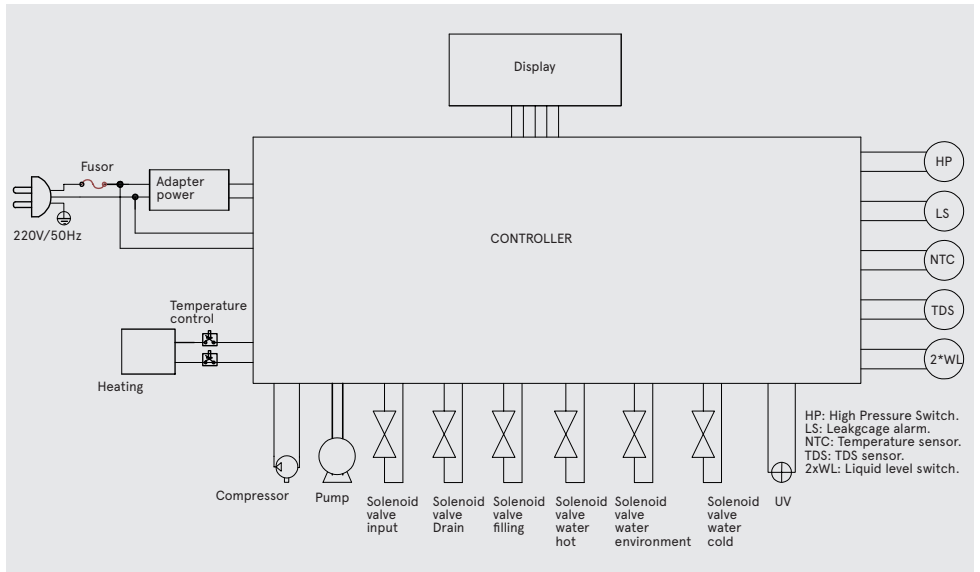

HYDRAULIC CONNECTION DIAGRAM MODEL RO

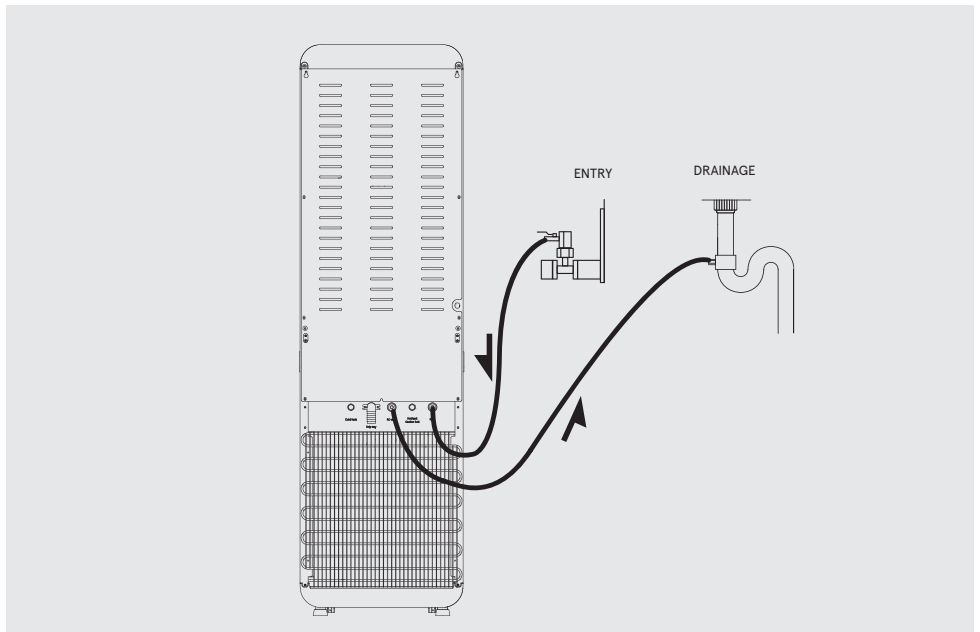

18. TROUBLESHOOTING

TANK DOES NOT FILL AT ALL		
Problem	Reason	Solution
1. No water enters the supply.	The stopcock is closed	Open the stopcock.
	The fountain is unplugged	Plug the fountain into the power supply.
	Turn the switch to ON.	Turn the switch to ON.
	No water supply	Problem not related to the source.
	Obstruction of the supply line to the source.	Replace feed tube.
2. Water enters the fountain, but does not reach the diaphragm.	Solenoid valve does not open	See item 3.
	There is a clogged filter	Disconnect the outlet of each filter one at a time to locate the clogged filter and replace it.
3. The solenoid valve does not open.	No power to the solenoid valve.	The tank is full and there is no water demand.
	The solenoid valve is damaged, since it receives current and does not open (Check with a voltmeter).	Replace the solenoid valve.
4. Solenoid valve and pump do not work.	Level switch does not work	See point 6.
5. Solenoid valve opens, but the pump does not operate.	Disconnected cable	Check for loose wires.
	Pump damaged	Replace the pump.
6. The level switch does not work.	It is damaged and does not respond to raising and lowering the float.	Replace the level switch.
	The electronic board is damaged	Replace the electronic board.
PRODUCTION IS LOW		
7. PRODUCTION IS LOW	Partial blockage of the sediment filter, comparing the inlet flow rate with the outlet flow rate of the sediment cartridge.	Replace the sediment filter.
	Partial blockage of the solenoid valve, comparing the inlet flow rate with the outlet flow rate of the solenoid valve.	Replace the solenoid valve
	Membrane is clogged	See point 8.
8. The membrane is clogged	The unit does not reject water	Replace the flow restrictor and the membrane.
	The membrane is more than 3 years old	Replace the membrane.
	The TDS of the inlet water is higher than 1500 ppm.	Contact technical service.

WATER KEEPS COMING OUT OF THE DRAIN		
9. The water source never stops spouting water down the drain.	Level switch does not respond to a full tank command (Check with a voltmeter).	Replace the level switch.
	Replace the inlet solenoid valve.	Replace the inlet solenoid valve.
WATER QUALITY IS NOT GOOD		
10. The water quality is not correct.	El caudal de rechazo es mucho menor a los 0,5 litros por minuto.	Replace the reject flow restrictor.
	Rejection flow rate is much less than 0.5 liters per minute.	Replace the membrane.
11. The water tastes bad.	The membrane has reached the end of its service life and no longer removes 90% of the salts from the inlet water.	Replace the afterfilter with a remineralizer cartridge.
	Taste is bitter, metallic or plastic and the output TDS is less than 25. Source is contaminated.	Perform a complete sanitization of the water supply.
THE FOUNTAIN DOES NOT COOL OR LITTLE COLD WATER IS COMING OUT.		
12. Water does not come out cold.	Rear switch (COLD) is in the OFF position.	Press switch to ON.
	Customer draws cold water bottles and empties the cold water reservoir.	The fountains are designed to draw water one cup at a time.
	Cooling system is damaged or refrigerant gas has been lost.	Remove the fountain for repair in the workshop.
FOUNTAIN DOES NOT HEAT OR TOO LITTLE HOT WATER COMES OUT.		
13. Water does not come out hot.	The rear switch (HOT) is in the OFF position.	Press the switch to ON.
	The hot water tank thermostat is damaged.	Replace the hot water tank thermostat.
	The heating element is damaged.	Replace the heating element.

4. WARRANTY

The distributor guarantees the equipment for a period of two years in the event of any non-compliance detected in the equipment, in accordance with Royal Decree 1/2007 of 16 November (revised text of the General Law for the Defence of Consumers and Users).

- The guarantee includes the repair and replacement of faulty parts by personnel authorised by the distributor or by the official technical assistance service (S.A.T.) at the place of installation or in its workshops. Included in the warranty is labor and shipping costs that may be generated.
- The distributor is exonerated from providing a guarantee in the case of parts subject to natural wear, lack of maintenance, blows or other nonconformities resulting from improper use of the equipment or inadequate according to the conditions and operating limits indicated by the manufacturer of the same. Likewise, the warranty becomes ineffective in cases of improper handling and use of the equipment or in those cases in which they have been modified or repaired by personnel outside the distribution company or official S.A.T..
- The parts replaced under warranty will remain the property of the distributor.
- The distributor is responsible for the lack of conformity of the equipment when it refers to the origin, identity or suitability of the products, according to their nature and purpose. Bearing in mind the characteristics of the equipment it is essential for the warranty to cover the lack of conformity, the fulfillment of the technical conditions of installation and operation. Failure to comply with these conditions may result in the absence of a warranty, taking into account the relevance of the destination of the equipment and the conditions and operating limits in which it must operate.
- The distributor must ensure that the installed equipment is suitable for improving the quality of the water to be treated in particular, according to the characteristics of the equipment and the regulations in force.
- The distributor must ensure the correct installation and start-up of the equipment as indicated by the manufacturer and current regulations and will also be liable for any lack of conformity resulting from incorrect application, installation or start-up of the equipment.
- For any warranty claim it is necessary to present the purchase invoice. The period of two years is calculated from the purchase of the equipment from the distributor.
- If there is a problem with your equipment during the warranty period, please contact your dealer.

The equipment is installed and operating to the customer's satisfaction and for the record:

* Pre-treatment of the equipment:

* Hardness of entry to the equipment (°F):

* TDS input to the equipment (ppm):

* TDS produced water (ppm):

* Pressure of entry to the equipment (bar):

*Result of the installation and commissioning sheet:

Correct:

Others:

The owner of the equipment has been properly and clearly informed of the use, handling and maintenance that the equipment requires to ensure its proper functioning and the quality of the water produced. A maintenance contract is offered for this purpose.

*Ref: Maintenance contract:

ACCEPTS the maintenance contract

DOES NOT ACCEPT the maintenance contract

If you need information, report a malfunction or malfunction, request for maintenance or intervention by a technician, please read the operation, troubleshooting and troubleshooting sections of this manual beforehand and contact the distributor or company that sold you your equipment.

COMPANY AND/OR AUTHORIZED INSTALLER, DATE AND SIGNATURE:

SERIAL NUMBER:



NOTE TO THE COMPANY AND/OR AUTHORIZED TECHNICIAN/INSTALLER: the data marked with the * symbol must be filled in by the installer and transcribed by him/herself from the INSTALLATION REGISTRATION sheet.



5. INSTALLATION REGISTER SHEET



NOTES TO THE TECHNICIAN/INSTALLER: read this manual carefully. If in doubt, contact your dealer's Technical Support Service (T.A.S.). The data marked with the symbol * must be filled in by the technician/installer and transcribed by him/herself to the WARRANTY page. This sheet must be kept by the installer and may be requested by the distributor in order to improve after-sales service and customer service. The technician who performs the installation and commissioning of the equipment must have adequate technical training.

INFORMATION ON THE USE OF THE EQUIPMENT:

Origin of the water to be treated:

PUBLIC SUPPLY NETWORK

OTHER _____

* Pre-treatment of the equipment: _____

* Hardness of entry to the equipment (°F): _____

* TDS of entry to the equipment (ppm): _____

* TDS produced water (ppm): _____

Inlet pressure to the equipment (bar): _____

INSTALLATION STEP CONTROL:

Pre-filter assembly: _____
Overflow installation: _____
Start-up according to protocol: _____
Checking of fittings: _____
Measurement of inlet hardness: _____
Output hardness measurement: _____

Installation of isolation by-pass: _____
Correct drainage installation: _____
Brine suction test/tank filling: _____
Leakage of the pressurised system: _____
Programming of the equipment: _____
Adjustment of residual hardness: _____

COMMENTS

* Result of installation and commissioning:

CORRECT (equipment installed and working correctly. Produced water suitable for the application).

OTHER: _____

IDENTIFICATION OF THE AUTHORISED TECHNICIAN/INSTALLER: CONFORMITY OF THE OWNER OF THE EQUIPMENT:

COMPANY AND/OR AUTHORIZED INSTALLER, DATE AND SIGNATURE: _____

I have been clearly informed of the use, operation and maintenance required by the installed equipment, having been offered a maintenance contract and informed of how to contact a customer service in the event of a request for information, communication of a breakdown or malfunction, request for maintenance or intervention by a technician.

Remarks: _____

*Ref: Maintenance contract: _____

ACCEPTS the maintenance contract

DOES NOT ACCEPT the maintenance contract

Model/Ref: _____

Owner: _____

Street _____

Telephone: _____

City: _____

Province: _____

C.P.: _____

SERIAL NUMBER

EQUIPMENT WARRANTY DIRECTED TO THE DISTRIBUTOR:

The distributor will only be responsible for the replacement of parts in the event of non-conformity. The repair of the equipment and the costs involved (labour, shipping costs, travel, etc.) will be borne by the distributor, in accordance with the general conditions of contract and sale, so it can not be passed on later to the manufacturer.



6. MAINTENANCE SERVICE

DATE	TYPE OF SERVICE	NAME, SIGNATURE AND STAMP OF TECHNICIAN	
<input type="text"/>	<input type="radio"/> START-UP		
<input type="text"/> <input type="text"/> <input type="text"/> <input type="text"/> <input type="text"/>	<input type="radio"/> COMPLETE MAINTENANCE <input type="radio"/> PREPARATION <input type="radio"/> SANITIZATION <input type="radio"/> OTHERS	TECHNICIAN <input type="text"/> STAMP <input type="text"/>	<input type="radio"/> ORDINARY <input type="radio"/> EXTRAORDINARY <input type="radio"/> WARRANTY
<input type="text"/> <input type="text"/> <input type="text"/> <input type="text"/>	<input type="radio"/> COMPLETE MAINTENANCE <input type="radio"/> PREPARATION <input type="radio"/> SANITIZATION <input type="radio"/> OTHERS	TECHNICIAN <input type="text"/> STAMP <input type="text"/>	<input type="radio"/> ORDINARY <input type="radio"/> EXTRAORDINARY <input type="radio"/> WARRANTY
<input type="text"/> <input type="text"/> <input type="text"/> <input type="text"/>	<input type="radio"/> COMPLETE MAINTENANCE <input type="radio"/> PREPARATION <input type="radio"/> SANITIZATION <input type="radio"/> OTHERS	TECHNICIAN <input type="text"/> STAMP <input type="text"/>	<input type="radio"/> ORDINARY <input type="radio"/> EXTRAORDINARY <input type="radio"/> WARRANTY
<input type="text"/> <input type="text"/> <input type="text"/> <input type="text"/>	<input type="radio"/> COMPLETE MAINTENANCE <input type="radio"/> PREPARATION <input type="radio"/> SANITIZATION <input type="radio"/> OTHERS	TECHNICIAN <input type="text"/> STAMP <input type="text"/>	<input type="radio"/> ORDINARY <input type="radio"/> EXTRAORDINARY <input type="radio"/> WARRANTY
<input type="text"/> <input type="text"/> <input type="text"/> <input type="text"/>	<input type="radio"/> COMPLETE MAINTENANCE <input type="radio"/> PREPARATION <input type="radio"/> SANITIZATION <input type="radio"/> OTHERS	TECHNICIAN <input type="text"/> STAMP <input type="text"/>	<input type="radio"/> ORDINARY <input type="radio"/> EXTRAORDINARY <input type="radio"/> WARRANTY

6. MAINTENANCE SERVICE

DATE	TYPE OF SERVICE	NAME, SIGNATURE AND STAMP OF TECHNICIAN	
<input type="text"/>	<input type="radio"/> START-UP		
<input type="text"/>	<input type="radio"/> COMPLETE MAINTENANCE	TECHNICIAN <input type="text"/>	<input type="radio"/> ORDINARY <input type="radio"/> EXTRAORDINARY <input type="radio"/> WARRANTY
<input type="text"/>	<input type="radio"/> PREPARATION	STAMP	
<input type="text"/>	<input type="radio"/> SANITIZATION	<input type="text"/>	
<input type="text"/>	<input type="radio"/> OTHERS		
<input type="text"/>	<input type="radio"/> COMPLETE MAINTENANCE	TECHNICIAN <input type="text"/>	<input type="radio"/> ORDINARY <input type="radio"/> EXTRAORDINARY <input type="radio"/> WARRANTY
<input type="text"/>	<input type="radio"/> PREPARATION	STAMP	
<input type="text"/>	<input type="radio"/> SANITIZATION	<input type="text"/>	
<input type="text"/>	<input type="radio"/> OTHERS		
<input type="text"/>	<input type="radio"/> COMPLETE MAINTENANCE	TECHNICIAN <input type="text"/>	<input type="radio"/> ORDINARY <input type="radio"/> EXTRAORDINARY <input type="radio"/> WARRANTY
<input type="text"/>	<input type="radio"/> PREPARATION	STAMP	
<input type="text"/>	<input type="radio"/> SANITIZATION	<input type="text"/>	
<input type="text"/>	<input type="radio"/> OTHERS		
<input type="text"/>	<input type="radio"/> COMPLETE MAINTENANCE	TECHNICIAN <input type="text"/>	<input type="radio"/> ORDINARY <input type="radio"/> EXTRAORDINARY <input type="radio"/> WARRANTY
<input type="text"/>	<input type="radio"/> PREPARATION	STAMP	
<input type="text"/>	<input type="radio"/> SANITIZATION	<input type="text"/>	
<input type="text"/>	<input type="radio"/> OTHERS		
<input type="text"/>	<input type="radio"/> COMPLETE MAINTENANCE	TECHNICIAN <input type="text"/>	<input type="radio"/> ORDINARY <input type="radio"/> EXTRAORDINARY <input type="radio"/> WARRANTY
<input type="text"/>	<input type="radio"/> PREPARATION	STAMP	
<input type="text"/>	<input type="radio"/> SANITIZATION	<input type="text"/>	
<input type="text"/>	<input type="radio"/> OTHERS		

